



Stay Active, Stay Healthy

Thank you for choosing DynaSpace!

Designed for all fitness levels, our treadmill combines cutting-edge technology with user-friendly features to help you reach your fitness goals, whether you're walking, jogging, or running.

DynaSpace

DynaSpace



Treadmill User's Manual

Read all precautions and instructions in this manual before using this equipment.

Keep this manual for future reference.

Note: The product photo is for reference only and may differ slightly from the actual product.



Model: SGC2100

	B) driving position hinder	Adjust driving position, or add oil
	C) motor short circuit	Change new motor
	D) pcb burnt	Change new pcb
E06	A) motor wire not well connected	Re-connect motor wire



A correct lubrication of the treadmill with silicon oil or teflon is REALLY IMPORTANT. This lubrication MUST BE PERFORMED REGULARLY DEPENDING ON EACH PERSON, EVEN BEFORE ITS FIRST USE.

YOU MUST PRESERVE THE ORIGINAL PACKAGING WITH ITS PROTECTIONS, PURCHASE RECEIPT, MANUAL AND COMPONENTS DURING THE GUARANTEE PERIOD.

IX. WARRANTY

We offer a one-year quality warranty on our products. During this warranty period, we provide free replacement parts. Please note that our company does not assume responsibility for issues resulting from incorrect assembly, improper use, or modifications to the product. To process a warranty claim, you must provide the product's serial number along with relevant pictures or information.

This treadmill is intended for home use only. Our company does not assume responsibility for problems arising from commercial use.

Contents

I. IMPORTANT PRECAUTIONS.....	(1)
II.MAIN TECHNICAL FEATURES	(4)
III. ASSEMBLY.....	(5)
IV.WORKOUT GUIDELINES	(7)
V.TREADMILL OPERATION.....	(8)
VI. MAINTENANCE.....	(11)
VII. RECYCLING INFORMATION.....	(13)
VIII.COMMON ERRORS	(14)
IX.WARRANTY.....	(15)



I. IMPORTANT PRECAUTIONS



The security key contains a magnet and must be inserted into the display. The clamp at the end of the lace should be attached to your clothing. The treadmill will only operate if the key is correctly placed in the display. This is essential.

Proper lubrication of the treadmill with silicone oil or Teflon is crucial. This lubrication must be performed regularly, depending on usage, and even before the first use.

WARNING:

You must retain the original packaging, including all protections, the purchase receipt, the manual, and all components throughout the warranty period.

To mitigate the risk of severe injury, please read all important instructions and warnings related to the use of the treadmill thoroughly before use. ZERO assumes no

VIII. COMMON ERRORS :

ERRO CODE	REASON	HOW TO SOLVE
NO DISPLAY	A) electricity not connected	Connect the electricity
	B) power switch not turn on	Turn on power switch
	C) pcb no power or broken	Press over-load protector or change new pcb
	D) signal wire not connected	Re-connect signal wire or change new one
	E) computer broken	Change new computer
	F) background light broken	Check background light wire or change new one
NOT DISPLAY ALL INFORMATION	A) display drive IC not inserted well	Re-insert IC, and re-weld it or change new one
	B) EMI gasket slip, not well fastened	Re-assemble screen
NOT RUN SMOOTHLY	A) driving position has resistance	Adjust driving position, or add some silicone oil
	B) running belt too tight or too loose	Adjust the belt tension
	C) pcb torque too big or too small	Ajust torque to right position
---	A) safety key off	Put on safety key
E01	A) signal wire not well connected	Re-connect signal wire
	B) signal wire broken	Change new signal wire
	C) signal wire broken	Change new computer
	D) pcb broken	Change new pcb
E02	A) motor wire not well connected, or open circuit	Re-connect motor wire or change new motor
	B) IGBT on pcb broken	Change new pcb
	C) input voltage too low	Stop using, ask electrician to check
E03	A) speed signal wire not well connected, or sensor broken	Re-connect speed signal wire or change new sensor wire
	B) pcb broken	Change new pcb
E04	A) incline motor wire not well connected	Re-connect incline motor wire
	B) incline motor broken	Change new incline motor
	C) pcb broken	Change new pcb
E05	A) over-loaded	Turn off and re-start machine

If the belt slips while walking on the treadmill, follow these steps:

1. Start the treadmill and increase the speed to 6km/h.
2. Using a 5mm wrench, turn both adjustment bolts 1/4 turn clockwise.
3. Ensure that the belt is tight enough for walking; you should be able to lift each side of the belt approximately 5 to 7 cm off the platform.
4. Be cautious to maintain the alignment of the belt while tightening.
5. Repeat this procedure as necessary until the belt is properly tightened.

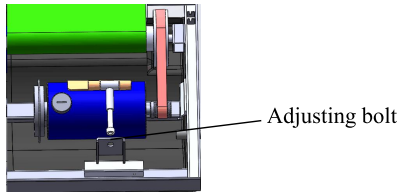

If the drive belt becomes loose after extended use, follow these steps:

1. Open the motor cover.
2. Use a 5mm wrench to turn the adjusting bolt clockwise.
3. Repeat this procedure until the drive belt no longer slips.

Cleaning: Avoid using abrasive products. A damp cloth is sufficient for cleaning.

Leveling: If your unit is equipped with leveling wheels, adjust them to prevent vibrations and potential malfunctions.

Keep These Maintenance Instructions for Future Reference.

VII. RECYCLING INFORMATION

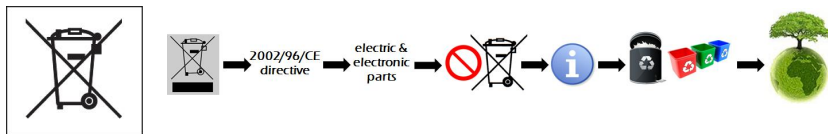

This electronic product must not be disposed of in municipal waste. To preserve the environment, this product must be recycled after its useful life as required by law.

responsibility for personal injuries or property damage resulting from the use of this product.

1. **Consult Your Doctor:** Prior to commencing any workout program, consult your physician. This is especially crucial for individuals over the age of 35, those with existing health conditions, and pregnant women.
2. **Inform Users:** The owner is responsible for ensuring that all users are adequately informed about the warnings and safety guidelines.
3. **Follow Manual Instructions:** Operate the equipment strictly in accordance with the instructions provided in the manual.
4. **Equipment Placement:** Keep the equipment in an enclosed area, protected from dust and humidity. Avoid storing it in a garage, indoor backyard, or near water, as exposure to these elements may cause malfunctions and void the warranty.
5. **Surface Stability:** Place the unit on a flat, stable surface. Uneven surfaces may affect the equipment's functionality. Some models feature levelers or leveling threads behind the legs to assist with leveling. Refer to the manual to determine if your unit includes these features.
6. **Ventilation:** Position the unit in a well-ventilated area. Do not use it in places with sprays or oxygen dispensers, as these may affect the air quality and increase the risk of accidents.
7. **Keep Clear of Children and Pets:** Ensure that children under the age of 12 and pets are kept away from the equipment, maintaining a safe distance at all times.
8. **Weight Capacity:** Consult the manual to confirm the maximum weight the equipment can support. Exceeding this weight may lead to malfunctions not covered by the warranty.
9. **Appropriate Attire:** Wear suitable clothing and footwear. Avoid loose clothing that may become entangled in the equipment.
10. **Power Supply:** If the equipment operates via a power supply, ensure that the power cord and plug are in good condition. Connect the equipment only to a properly grounded circuit to prevent damage that may not be covered by the warranty. Keep power cords away from hot surfaces.
11. **Battery-Powered Units:** For battery-powered equipment, verify that the batteries are sufficiently charged to ensure proper display functionality.
12. **Safety Key:** If the equipment includes a safety key, familiarize yourself with its operation before use. The safety key, which has a magnet, must be inserted into the display. Attach the clamp at the end of the lace to your clothing. The treadmill will operate only when the key is properly placed in the display. This step is essential.
13. **Power Supply Operation:** When using a power-supplied unit, avoid starting the machine while on the belt, as this may place unnecessary strain on the motor. Stand with your feet on either side of the belt and begin exercising once the equipment is operational.

14. **Speed Adjustment:** If the unit operates on an electric supply, check the maximum speed it can reach for safety. Gradually adjust the speed to avoid sudden changes.
15. **Supervision:** Do not leave the equipment unattended while it is in operation. Remove the safety key, turn the power switch to the “off” position, and unplug the power cord when not in use.
16. **Pulse Sensor:** If the equipment includes a pulse sensor, note that it is not a medical instrument. It is intended to assist with workout monitoring and may be affected by user movement, which could impact accuracy.
17. **Folding and Storage:** The equipment can be folded for storage. Ensure that all components are securely assembled with the locking system, whether it uses a lock or a hydraulic mechanism. Avoid moving or lifting the unit unless you are certain it is securely locked. Damage occurring due to improper handling will not be covered by the warranty.
18. **Regular Maintenance:** Regularly check and tighten all screws, as vibrations can cause them to loosen. Damage resulting from a lack of maintenance is not covered by the warranty.
19. **Lubrication:** Proper lubrication with silicone oil or Teflon is crucial. Lubricate the treadmill regularly, including before its first use. To lubricate, disconnect the equipment from the power supply (if applicable), lift the belt on one side, and apply oil to the board. Repeat this on the other side. Reconnect the power supply (if applicable), turn the power switch to the “on” position, insert the safety key, and allow the treadmill to run for several minutes without weight. Perform this maintenance regularly.
20. **Unpacking:** Two people are required to remove the unit from the package. Damage occurring during this process will not be covered by the warranty.
21. **Avoid Obstructions:** Ensure that no objects fall into the grooves of the equipment.
22. **Unplug Before Cleaning:** Always unplug the power cord before cleaning the equipment, after use, and before performing any maintenance.
23. **Intended Use:** This equipment is designed for domestic use in indoor settings only, not for commercial environments or outdoor use.
24. **Pre-Workout and Post-Workout Stretches:** Perform stretches before and after workouts to prevent injuries.
25. **Hydration:** Drink water before, during, and after workouts.
26. **Stop If Unwell:** If you experience pain or dizziness during exercise, stop immediately.
27. **Preserve Original Packaging:** Retain the original packaging, including protections, manual, and components throughout the warranty period.
28. **Accessory Variations:** Accessories may vary between different models.
29. **Proper Disposal:** This electronic product should not be disposed of in municipal trash bins. To protect the environment, recycle the product according to your country’s applicable laws. Contact your local council for information on recycling procedures.

• **ALIGN AND TIGHTEN THE BELT OF THE TREADMILL**

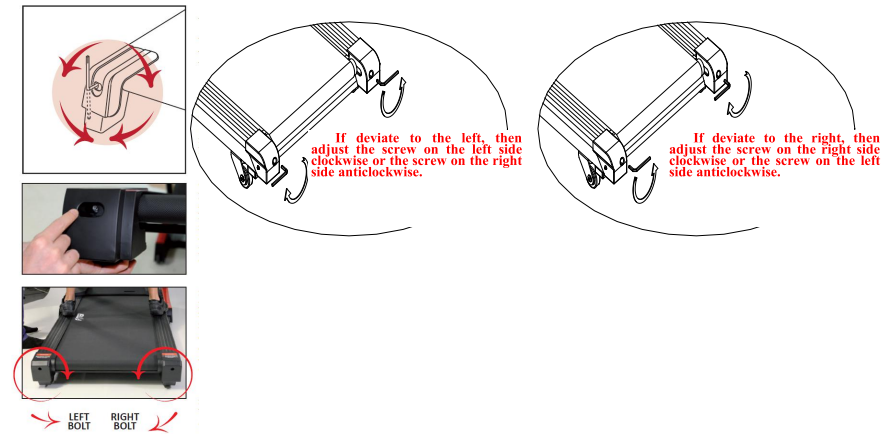

Over time, the belt may shift off-center due to use. If the belt has moved to the left, follow these steps:

1. Start the treadmill and increase the speed to 6km/h.
2. Use a 5mm wrench to turn the left adjustment bolt clockwise or the right adjustment bolt counterclockwise as needed.
3. Avoid overtightening the belt to ensure it remains suitable for walking.
4. Repeat the adjustment process until the belt is properly aligned.

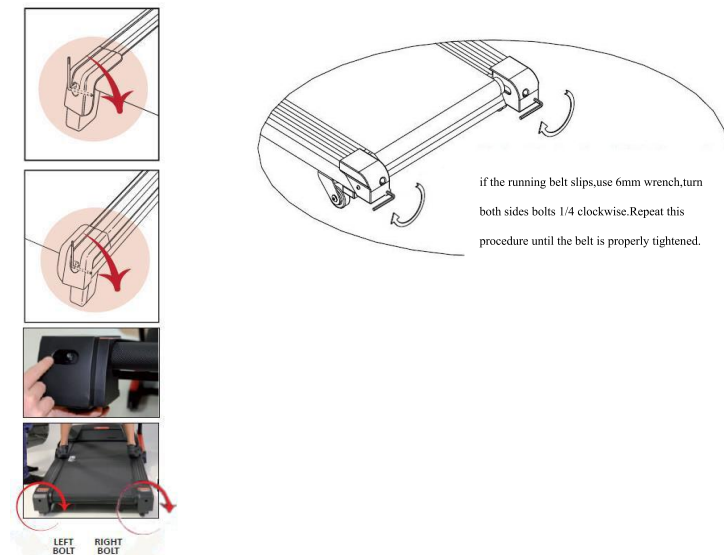

VI. MAINTENANCE

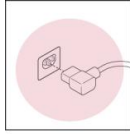

This product must be properly grounded. If the power cord is damaged, it must be replaced with a manufacturer-recommended power cord.

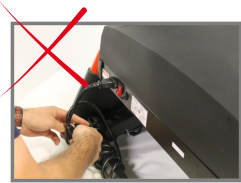
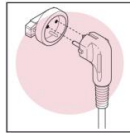

DO NOT TANGLE THE POWER CORD

REGULAR MAINTENANCE OF THE TREADMILL

- **Storage:** Store your equipment in an enclosed area, protected from dust and humidity. Avoid placing it in a garage, indoor backyard, or near water. Exposure to humidity, dust, and water can damage the equipment and impact its functionality.
- **Electric Cable:** Ensure that the power cable and plug are in excellent condition. Keep electric cables away from hot surfaces.
- **Screws and Connecting Cables:** Regularly inspect and tighten screws, as vibrations can cause them to loosen over time.
- **Lubrication:** Proper lubrication of the treadmill with silicone oil or Teflon is crucial. Lubricate the treadmill regularly, including before its first use. Locate the oil addition hole on the motor cover. Start the machine, set it to the highest speed, and add oil through the hole. The oil will distribute evenly between the running belt and the board.

< 3 hours/week	2 months
4 - 7 hours/week	1 month
> 8 hours/week	15 days



30. Technical Assistance: For technical support or installation advice, please contact us.

KEEP THE PURCHASE RECEIPT IN ORDER TO HAVE ACCESS TO THIS SERVICE. Keep these guidelines for future reference

II. MAIN TECHNICAL FEATURES

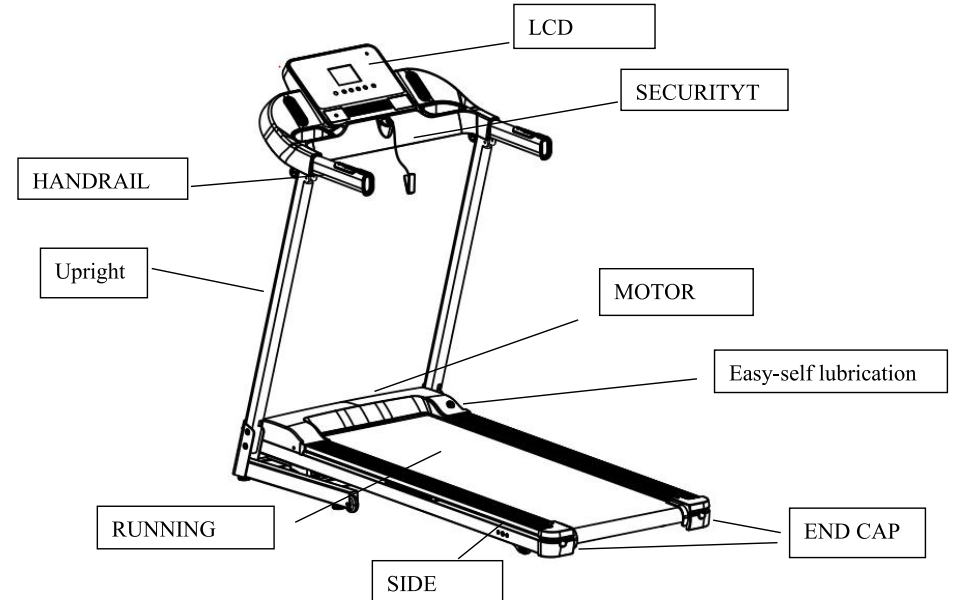







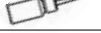

Input Voltage	220V±10%
Frequency	50/60 HZ
Running area	1210X410mm
Function	Time, Speed, distance, Calorie, heart rate, bluetooth app, MP3&speakers
Speed Range	1.0-14KM/H
Max user weight	100kgs
Power	1.75HP

III. ASSEMBLY



NOTICE:ASSEMBLY REQUIRES TWO

No.	Fittings	Qty
1	M8 knob 	2
2	M8×20 screw 	2
3	Silicone oil 	1
4	M8*40 screw 	2
5	5mm wrench 	1
6	M8 washer 	4
7	Multi- wrench 	1
8	Main frame 	1

STEP 1

Open the carton and remove the entire unit. Then, lift the panel and upright in the direction indicated by arrow A.

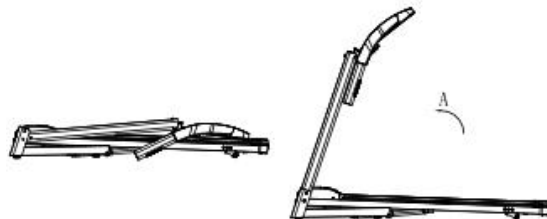

STEP 2

Use 2pcs M8*20 screws with washers to secure the front end of the Upright.

Then, use 2pcs M8*40 screws with washers, passing them through the Upright to firmly attach it.

CONSTITUTION TEST

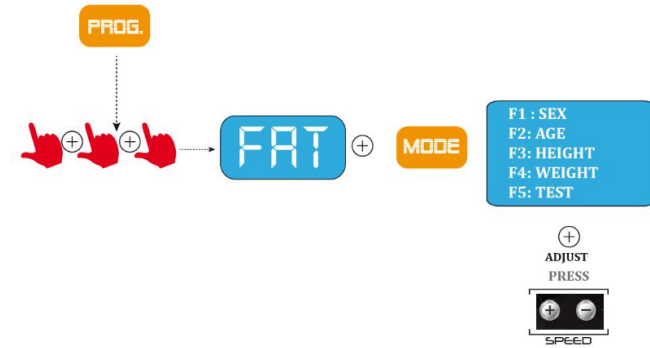

01	Sex	01 M	02 F
02	Age	10-----99	
03	Height	100-----240	
04	Weight	20-----160	
05	FAT	≤19	Underweight
	FAT	=(20--25)	Normal weight
	FAT	=(25--29)	Overweight
	FAT	≥30	Obesity

BLUETOOTH APP



PROGRAM

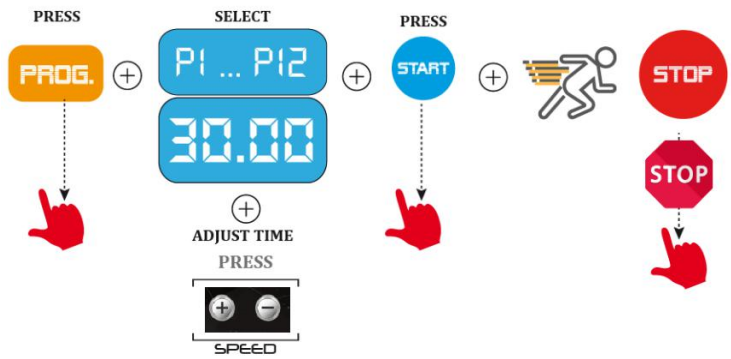

TIME SECTION PROGRAM	SETTING TIME / 20= EACH SECTION OPERATION TIME																				
	1	2	3	4	5	6	7	8	9	10	11	12	13	14	15	16	17	18	19	20	
P01	SPEED	2	3	3	4	5	3	4	5	5	3	4	5	4	4	4	2	3	3	5	3
P02	SPEED	2	4	4	5	6	4	6	6	6	4	5	6	4	4	4	2	2	5	4	1
P03	SPEED	2	4	4	6	6	4	7	7	7	4	7	7	4	4	4	2	4	5	3	2
P04	SPEED	3	5	5	6	7	7	5	7	7	8	8	5	8	5	5	6	6	4	4	3
P05	SPEED	2	4	4	5	6	7	7	5	6	7	8	8	5	4	3	3	6	5	4	2
P06	SPEED	2	4	3	4	5	4	8	7	5	7	8	3	6	4	4	2	5	4	3	2
P07	SPEED	2	3	3	3	4	5	3	4	5	3	4	5	3	3	3	6	6	5	3	3
P08	SPEED	2	3	3	6	7	7	4	6	7	4	6	7	4	4	4	2	3	4	4	2
P09	SPEED	2	4	4	7	7	4	7	8	4	8	8	8	4	4	4	5	6	3	3	2
P10	SPEED	2	4	5	6	7	5	4	6	8	8	6	6	5	4	4	2	4	4	3	3
P11	SPEED	3	4	5	8	5	8	5	5	5	8	5	5	5	5	8	8	8	7	6	3
P12	SPEED	2	5	8	8	7	7	8	8	7	7	8	8	6	6	8	8	5	5	4	3

P12 Program Exercise Program

MP3 MUSIC

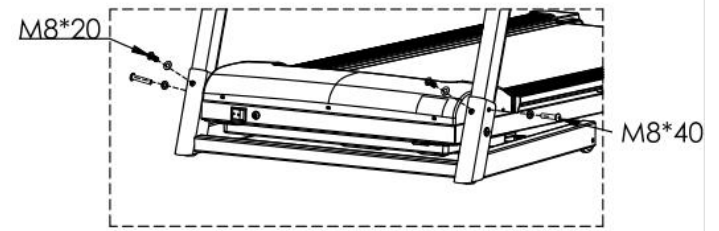

STEP 3

Raise the computer panel to the angle indicated, then insert 2pcs M8 knobs and tighten them

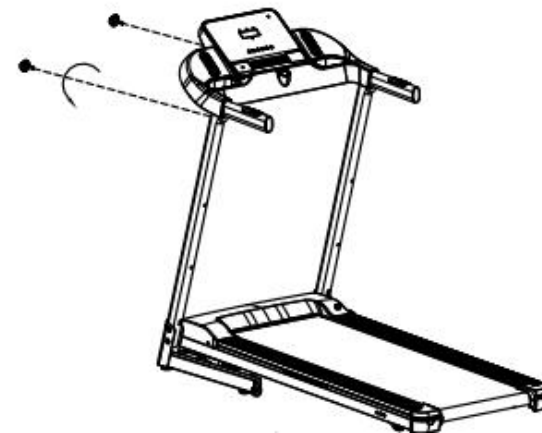

A

ttac
hme
nt 1:
P1-

IV. WORKOUT GUIDELINES

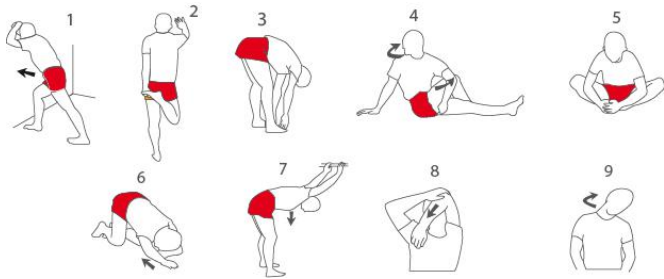

Beware: Before beginning this or any exercise program, consult your physician. This is especially important for individuals over the age of 35 or those with existing health conditions.

If your equipment is equipped with a pulse sensor, please note that it is not a medical device. Several factors may affect the accuracy of heart rate measurements. The pulse sensor is intended to assist with workouts by providing general trends in heart rate.

Program with Warm-Up Workouts:

- **Warm-Up:** Begin with 5 to 10 minutes of stretching and light muscle activation. This warm-up will elevate your body temperature, increase your heart rate, and enhance blood flow, preparing you for the workout.
- **Workout Focused on the Training Area:** Engage in exercises for 20 to 30 minutes, ensuring that your heart rate does not exceed 20 minutes of continuous exertion during the initial weeks of your exercise program. Breathe steadily and deeply throughout the workout; do not hold your breath.
- **Cool Down:** Conclude with 5 to 10 minutes of stretching exercises. Stretching improves muscle flexibility and helps prevent injuries following workouts.

Frequency of Workouts: To achieve fitness or improve your physical condition, aim for three workout sessions per week with a rest day between sessions. After several months of consistent training, you may increase to up to five workouts per week.

V. TREADMILL OPERATION

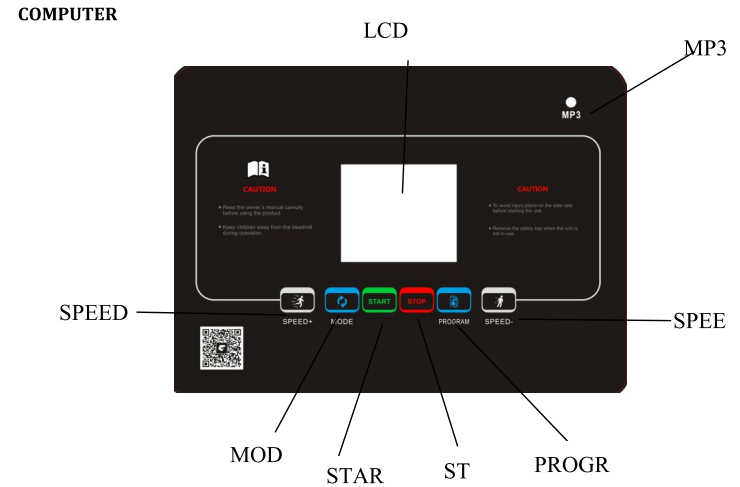

MANUAL

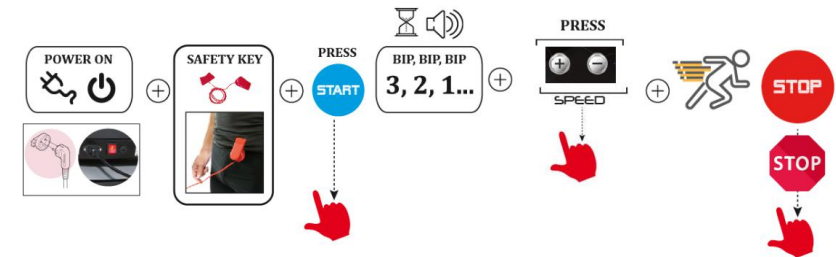

MODE

